

MOTLOW STATE COMMUNITY COLLEGE ADDITIONAL PARKING AND ROADWAY REPAIRS

MOORE COUNTY, TENNESSEE

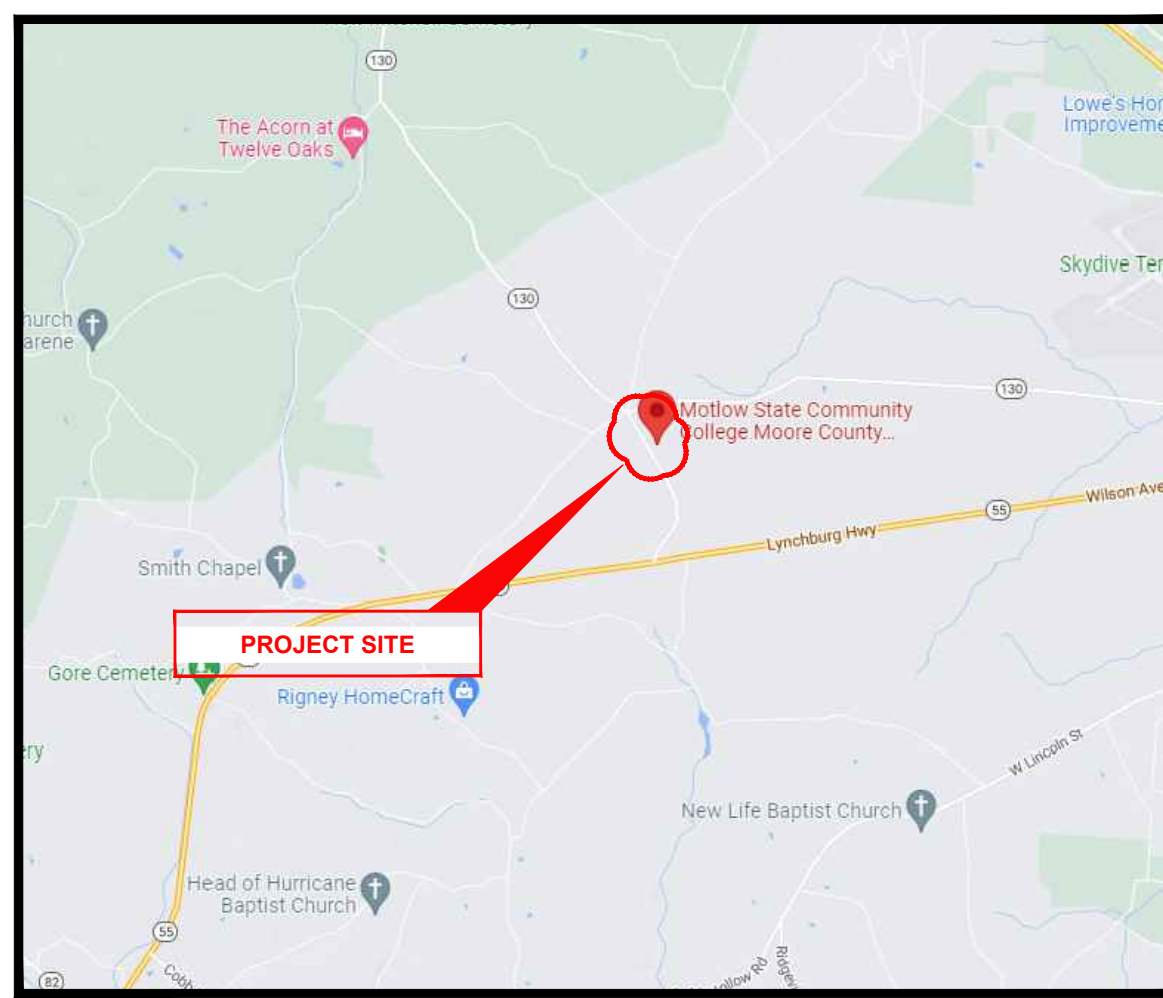

VICINITY MAP

6015 LEDFORD MILL RD
TULLAHOMA, TN 37388

CT JOB # 220439
SBC NO. 166/021-01-2022

INDEX OF SHEETS	
NO.	SHEET NAME
C1	TITLE
C2	NOTES & LEGEND
C3	DETAILS
C4	EXISTING CONDITIONS
C5	SITE LAYOUT - PARKING LOT A
C6	ALTERNATE 2 - PARKING LOT B
C7	ALTERNATE 3 - PARKING LOT D

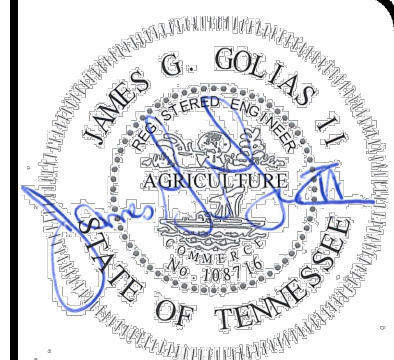

your trusted advisor
consultants
engineers
architects
planners

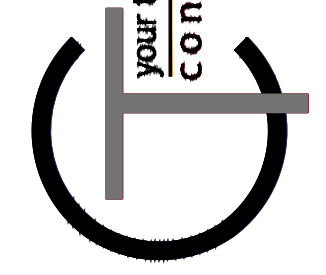

QUANTITY NOTES
QUANTITIES SHOWN ARE FOR REFERENCE. CONTRACTOR IS RESPONSIBLE FOR VERIFYING QUANTITIES AND INFORMING THE OWNER/DESIGNER OF DISCREPANCIES PRIOR TO CONTRACT AWARD.
RESEAL: 404,800 SQ FT
MILL AND RESURFACE: 5,500 SQ FT
STRIPING: 24,414 LINEAR FT
ADA SYMBOLS: 30
TRAVERSE STRIPING AREA: 7,783 SQ FT
STOP BARS: 3
PAINTED SYMBOLS: 2,586 CHARACTERS

NOTES
FINAL LIMITS OF PAVEMENT REMOVE TO BE FIELD VERIFIED BY CONTRACTOR AND OWNER PRIOR TO CONSTRUCTION
PARKING CALCULATION:
ADA PARKING REQUIREMENT: 23 ADA SPACES
TOTAL PARKING SPACES PROVIDED: 1243
TOTAL ADA SPACES: 35 ADA SPACES



SITE MAP

PROJECT CONTACTS	
SITE ENGINEER JAMES G. GOLIAS II, P.E. 615-349-4025 JGOLIAS@CTCONSULTANTS.COM 2964 SIDCO DRIVE NASHVILLE, TN 37204	DATE
PROPERTY OWNER TENNESSEE BOARD OF REGENTS 1 BRIDGESTONE PARK NASHVILLE, TN 37214 615-366-4400 TRISH WHITLOCK, PROJECT MANAGER TRISH.WHITLOCK@TBR.EDU	REVISION
SCHOOL CONTACT MOTLOW STATE COMMUNITY COLLEGE PO BOX 8500 LYNCHBURG, TN 37352 931-393-1576 BRIAN GAFFORD, P.E., DIRECTOR OF FACILITIES SERVICES BGAFFORD@MSCC.EDU	NO

ZONING INFORMATION	
OWNER: MOTLOW STATE COMMUNITY COLLEGE PROPERTY ADDRESS: 6015 LEDFORD MILL ROAD TULLAHOMA, TN 37388	ISSUED FOR: CONSTRUCTION
PARCEL NUMBER: 007 023.00	ISSUE DATE: 01/19/2024
TOTAL ACREAGE: 187.23 ACRES	SCALE:
ACREAGE DISTURBED: 0 ACRES	DESIGNED BY: MHOR
	DRAWN BY: MHOR
	CHECKED BY: JGOL

SOURCE OF BOUNDARY INFORMATION
THE BOUNDARY INFORMATION SHOWN ON THESE PLANS IS BASED UPON MOORE COUNTY G.I.S. MAPPING AND DOES NOT REPRESENT AN ACTUAL FIELD BOUNDARY SURVEY BY CT CONSULTANTS, INC.



DATE	REVISION	NO	ISSUED FOR: CONSTRUCTION	ISSUE DATE:	SCALE:	DESIGNED BY:	DRAWN BY:	CHECKED BY:
				01/19/2024		MHOR	MHOR	JGOL

**MOTLOW STATE COMMUNITY COLLEGE
ADDITIONAL PARKING AND ROADWAY REPAIRS
TULLAHOMA, TENNESSEE 37388**

SBC NO. 166/021-01-2022

TITLE SHEET

PROJECT NO.	220439
DISCIPLINE	CIVIL
SHEET NAME	C1
SHEET	1
OF	7

GENERAL NOTES

- ALL CONSTRUCTION SHALL CONFORM TO THESE PLANS AND SPECIFICATIONS, THE LATEST EDITION OF THE STATE OF TENNESSEE DEPARTMENT OF TRANSPORTATION (TDOT) CONSTRUCTION AND MATERIAL SPECIFICATIONS AND IN ACCORDANCE WITH METROPOLITAN NASHVILLE STORMWATER MANAGEMENT MANUAL.
- THERE SHALL BE NO DEVIATION FROM THE APPROVED PLANS WITHOUT PRIOR WRITTEN APPROVAL FROM THE OWNER OR THEIR REPRESENTATIVE. ANY DEVIATION FROM THESE PLANS WITHOUT PRIOR WRITTEN APPROVAL SHALL BE AT THE CONTRACTOR'S RISK AND EXPENSE.
- THE CONTRACTOR SHALL OBTAIN THE SERVICES OF A TESTING AGENCY FOR ALL REQUIRED TESTING.
- THE CONTRACTOR SHALL REVIEW THE SUBSURFACE EXPLORATION AND GEOTECHNICAL ENGINEERING REPORT PREPARED BY EGS SOUTH/EAST LLP AND DATED MAY 5 2023, AND ANY SUBSEQUENT REVISIONS. A COPY OF THIS REPORT WILL BE MADE AVAILABLE TO THE CONTRACTOR THROUGH THE OWNER. THE CONTRACTOR SHALL ADHERE TO ALL ASPECTS AND RECOMMENDATIONS OF THE REPORT.
- THE CONTRACTOR SHALL BE RESPONSIBLE FOR ALL CONSTRUCTION LAYOUT STAKING INCLUDING HORIZONTAL AND VERTICAL CONTROL. ANY DISCREPANCIES DISCOVERED IN THE PLAN INFORMATION OR BETWEEN THE PLAN AND ELECTRONIC DATA SHALL BE BROUGHT TO THE IMMEDIATE ATTENTION OF THE DESIGN ENGINEER SO THE APPROPRIATE ADJUSTMENTS MAY BE MADE.
- ALL WORK SHALL BE LIMITED TO THE PROPERTIES AND EASEMENTS IDENTIFIED ON THE PLANS. ANY WORK WITHIN THE PUBLIC RIGHT OF WAY IS SUBJECT TO INTERFERING WITH ANY EXISTING PERMITS FROM THE JURISDICTION HAVING AUTHORITY OVER THE RIGHT-OF-WAY. REQUIREMENTS OF SUCH PERMITS ARE INCORPORATED INTO THESE DOCUMENTS BY REFERENCE.
- ANY DEFECTS IN CONSTRUCTION, INCLUDING MATERIALS OR WORKMANSHIP, SHALL BE REPLACED OR CORRECTED BY THE CONTRACTOR BY REMOVAL AND REPLACEMENT OR OTHER APPROVED METHODS PRIOR TO ACCEPTANCE BY THE OWNER WITH NO ADDITIONAL COMPENSATION.
- CONTRACTOR SHALL SUBMIT A PLAN OF OPERATIONS FOR REVIEW AND APPROVAL BY THE ARCHITECT THAT WILL INDICATE EQUIPMENT STAGING AREAS, STOCKPILE LOCATION AND SANITATION FACILITIES.
- RIGHT-OF-WAY AND PROPERTY LINES SHOWN ARE PLOTTED FROM MOORE COUNTY G.I.S. MAPPING AND ARE APPROXIMATE AND NOT THE RESULT OF A FIELD BOUNDARY SURVEY.
- ALL OSHA, STATE AND LOCAL SAFETY REGULATIONS SHALL BE FOLLOWED DURING CONSTRUCTION.
- APPROPRIATE BARRICADES, WARNING LIGHTS, SIGNS, FENCING ETC. SHALL BE ERECTED AROUND THE CONSTRUCTION AREA DURING NON-WORKING HOURS TO ALERT PERSONS OF THE POTENTIAL DANGER ASSOCIATED WITH THE AREA UNDER CONSTRUCTION AS WELL AS TO PREVENT ACCESS BY UNAUTHORIZED PERSONNEL. THE CONTRACTOR IS RESPONSIBLE FOR ENSURING THE SAFETY OF THE GENERAL PUBLIC AS WELL AS ALL CONSTRUCTION PERSONNEL.
- ANY EXISTING ROADWAY, LAWN, CURB, SIDEWALK OR OTHER APPURTENANCE DISTURBED DURING CONSTRUCTION NOT DESIGNATED FOR REMOVAL OR REPLACEMENT SHALL BE RESTORED BY THE CONTRACTOR WITHOUT ADDITIONAL COMPENSATION TO A CONDITION EQUAL TO OR BETTER THAN THAT WHICH EXISTED PRIOR TO DISTURBANCE.
- ANY TEMPORARY UTILITY REQUIRED BY THE CONTRACTOR (ELECTRIC, WATER ETC.) SHALL BE AT THE SOLE EXPENSE OF THE CONTRACTOR.
- THE CONTRACTOR SHALL PRESERVE ALL BENCHMARKS, PROPERTY LINE REFERENCES, REFERENCE POINTS, STAKES AND ANY OTHER SURVEY REFERENCE. IN CASE OF DISTURBANCE THE CONTRACTOR SHALL REPLACE THEM AT THE CONTRACTOR'S EXPENSE. BE RESPONSIBLE FOR ANY ERRORS THAT MAY BE CAUSED BY THEIR LOSS OR DISTURBANCE.
- ALL PROPOSED CONCRETE PAVEMENT ABUTTING EXISTING PAVEMENT SHALL BE DOWELED INTO EXISTING CONCRETE PAVEMENT USING A ½" DEFORMED DOWEL WITH 9" MINIMUM EMBEDMENT.
- THE CONTRACTOR SHALL COMPLY AT ALL TIMES WITH APPLICABLE FEDERAL, STATE AND LOCAL LAWS, PROVISIONS, AND POLICIES GOVERNING SAFETY AND HEALTH, INCLUDING THE FEDERAL CONSTRUCTION SAFETY ACT (PUBLIC LAW 91-54), FEDERAL REGISTER, CHAPTER XVII, PART 1926 OF TITLE 29 REGULATIONS, OCCUPATIONAL SAFETY AND HEALTH REGULATIONS FOR CONSTRUCTION, AND SUBSEQUENT PUBLICATIONS UPDATING THESE REGULATIONS.
- THE CONTRACTOR SHALL BE RESPONSIBLE FOR EXAMINING THE AREAS AND CONDITIONS UNDER WHICH THE PROJECT IS TO BE CONSTRUCTED PRIOR TO THE SUBMISSION OF THE BID. SUBMISSION OF A BID SHALL BE CONSTRUED TO MEAN THE CONTRACTOR HAS REVIEWED THE SITE AND IS FAMILIAR WITH THE CONDITIONS AND CONSTRAINTS OF THE SITE.
- CONTRACTOR SHALL REFER TO OTHER PLANS WITHIN THIS CONSTRUCTION SET FOR OTHER PERTINENT INFORMATION.

ACCESSIBILITY NOTES

- ALL REQUIREMENTS OF THE AMERICANS WITH DISABILITIES ACT (ADA) SHALL BE FOLLOWED IN ALL ASPECTS OF THE PROJECT.
- ALL SIDEWALKS INSTALLED SHALL HAVE A MAXIMUM CROSS SLOPE OF 2%
- HANDICAP ACCESSIBLE PARKING SPACES SHALL NOT EXCEED A SLOPE OF 2% IN ANY DIRECTION
- ALL CURB RAMPS SHOWN ALONG A DESIGNATED ACCESSIBLE ROUTE SHALL BE FLUSH WITH THE ADJACENT PAVEMENT.

UTILITY NOTES

- THIS PLAN SHOWS THE APPROXIMATE LOCATION OF UNDERGROUND UTILITIES (GAS, WATER, STORM SEWER, SANITARY SEWER, TELEPHONE, ELECTRIC, ETC.). THE PREPARER DOES NOT GUARANTEE THEIR ACCURACY OR CORRECTNESS. THE INFORMATION PROVIDED SHALL BE FIELD VERIFIED PRIOR TO CONSTRUCTION. THE CONTRACTOR SHALL BE RESPONSIBLE FOR MAINTAINING THE UTILITY AS WELL AS THE SERVICE LATERALS AT ALL TIMES DURING CONSTRUCTION. THE CONTRACTOR SHALL PRACTICE CARE DURING THE GRADING AND TRENCH EXCAVATION AND SHALL BE RESPONSIBLE FOR REPLACING ANY SERVICES THAT ARE DAMAGED DURING CONSTRUCTION AT THEIR EXPENSE.
- PRIOR TO ANY EXCAVATION OVER AN EXISTING UTILITY LINE OR SERVICE, CONTRACTOR SHALL HAND EXCAVATE TO EXPOSE THE UTILITY AND DETERMINE LOCATION AND DEPTH. NOTIFY ENGINEER IMMEDIATELY OF ANY CONFLICTS.
- TOPS OF EXISTING AND PROPOSED CASTING ELEVATIONS ARE SUBJECT TO FINAL ADJUSTMENTS AS APPROVED BY THE ENGINEER AND REQUIREMENTS OF UTILITY OWNER. THIS WORK WILL BE INCIDENTAL TO THE CONTRACT.
- FORTY-EIGHT (48) HOURS BEFORE EXCAVATION IS TO COMMENCE, THE CONTRACTOR SHALL NOTIFY THE FOLLOWING AGENCIES: THE TENNESSEE UTILITY PROTECTION SERVICE AND ALL OTHER UTILITIES THAT MAY HAVE UNDERGROUND UTILITIES INVOLVING THIS PROJECT AND ARE NON-MEMBERS OF KENTUCKY UNDERGROUND PROTECTION.
- THE SITE MAY CONTAIN EXISTING PRIVATELY OWNED UTILITIES. THESE HAVE BEEN SHOWN AS ACCURATELY AS POSSIBLE BASED ON EXISTING UTILITY INFORMATION, BUT THE PREPARER OF THESE DOCUMENTS DOES NOT ATTEST TO THEIR ACCURACY OR CORRECTNESS. IT SHALL BE THE CONTRACTOR'S RESPONSIBILITY TO CONTRACT WITH A PRIVATE UTILITY MARKING AGENCY TO IDENTIFY AND LOCATE ALL PRIVATE UTILITIES WITHIN THE WORK SITE. THIS MAY INVOLVE THE EXCAVATION AND UNCOVERING OF UTILITIES TO VERIFY LOCATION. NOTIFY ENGINEER IMMEDIATELY OF ANY CONFLICTS. CONTRACT SHALL MAKE RECORDS OF ALL PRIVATE UTILITIES ENCOUNTERED DURING THE PROJECT.
- RECORD DRAWINGS OF NEW UTILITY SERVICES SHALL BE PREPARED BY THE CONTRACTOR AND SUBMITTED TO THE OWNER UPON COMPLETION OF THE PROJECT.

EXISTING CONDITIONS AND DEMOLITION NOTES

- THE CONTRACTOR MUST CONTACT TENNESSEE811 AT LEAST 3 DAYS, BUT NO MORE THAN 10 WORKING DAYS, BEFORE BEGINNING ANY DIGGING, EXCLUDING SATURDAYS, SUNDAYS AND OTHER LEGAL HOLIDAYS. NON-MEMBER UTILITIES MUST BE CONTACTED DIRECTLY. THE CONTRACTOR SHALL COORDINATE THE MARKING AND/OR LOCATING TO STAY A MINIMUM OF TWO WORKING DAYS AHEAD OF PLANNED CONSTRUCTION ACTIVITIES.
- THE CONTRACTOR SHALL REMOVE ALL SURPLUS MATERIAL, DEMOLISHED MATERIALS AND WASTE MATERIALS INCLUDING TREES, STUMPS, BRUSH, TRASH AND DEBRIS, FROM THE PROJECT LIMITS AND LEGALLY DISPOSE OF OFF-SITE.
- IF ADJACENT PAVEMENT IS DAMAGED, THE CONTRACTOR SHALL MAKE SAWCUTS, REMOVE THE DAMAGED AREAS AND REPAIR AS NECESSARY WITH NO ADDITIONAL COMPENSATION.

SIGNAGE NOTES

- ALL SIGNS SHALL MEET THE REQUIREMENT OF THE MANUAL OF UNIFORM TRAFFIC CONTROL DEVICES (MUTCD).
- ALL SIGNS ARE 12"x18" UNLESS NOTED OTHERWISE.
- ALL SIGNS SHALL HAVE REFLECTIVE MATERIAL PER MUTCD.

LEGEND

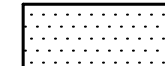
 CRACK SEAL AND SEAL COAT PAVEMENT

 1.5" MILL AND OVERLAY PER DETAIL SHT. 3

MAINTENANCE OF TRAFFIC NOTES

- ALL MAINTENANCE OF TRAFFIC PROCEDURES SHALL MEET THE REQUIREMENT OF THE MANUAL OF UNIFORM TRAFFIC CONTROL DEVICES. THE CONTRACTOR SHALL MAINTAIN ACCESS TO LOCAL TRAFFIC (ACCESS TO RESIDENCES WITHIN CONSTRUCTION LIMITS) AT ALL TIMES. THE CONTRACTOR SHALL PROVIDE SUFFICIENT SIGN, WARNING LIGHTS, BARRICADES, OR OTHER NECESSARY DEVICES MAKE THE SITE SAFE TO THE TRAVELING PUBLIC.
- IT SHALL BE THE CONTRACTOR'S RESPONSIBILITY TO SUBMIT TO THE ENGINEER AND THE OWNER A TRAFFIC CONTROL PLAN FOR THIS PROJECT.
- RESIDENTS OF THE PROJECT AREA SHALL BE ALLOWED ACCESS TO THEIR PROPERTY AT ALL TIMES.
- ALTERNATE ROUTES OR CONTINUOUS TRAFFIC CONTROL SHALL BE EMPLOYED WHEN A PUBLIC WAY IS TEMPORARILY BLOCKED DURING CONSTRUCTION, INCLUDING PEDESTRIAN AND BICYCLE FACILITIES. ADVANCED NOTICE SIGNS IN ACCORDANCE WITH THE MUTCD SHALL BE EMPLOYED.

PAINT STRIPING NOTES

- PAINT STRIPING SHALL BE INSTALLED TO MATCH EXISTING EXCEPT THAT ACCESSIBLE PARKING SPACES SHALL BE INSTALLED TO MEET MOST CURRENT ADA REQUIREMENTS. VAN ACCESSIBLE SPOT(S) SHALL BE INSTALLED PER ADA REQUIREMENTS. ALL WORK SHALL BE PERFORMED IN ACCORDANCE WITH SECTION 716.03 OF THE 2021 TDOT STANDARD SPECIFICATION FOR ROAD AND BRIDGE CONSTRUCTION AND ANY OTHER SECTIONS APPLICABLE AND THE FEDERAL HIGHWAY ADMINISTRATION "MANUAL OF UNIFORM TRAFFIC CONTROL DEVICES.
- THERMOPLASTIC PAVEMENT MARKING SHALL BE USED FOR STOP BARS, CROSSWALKS, AND DIRECTIONAL ARROWS AS DEFINED BY SECTION 716.03 FOR WHITE STRIPES AND MARKING PER THE 2021 TDOT STANDARD SPECIFICATION FOR ROAD AND BRIDGE CONSTRUCTION.
- ALL OTHER PAINT MARKING SHALL BE 4" WIDE STRIPING PAINTED WHITE

VEGETATION REMOVAL

- VEGETATION GROWING THROUGH THE SURFACE OF THE PAVEMENT BEING PREPARED FOR CRACK SEALING AND/OR SEAL COATING SHALL BE REMOVED AND STERILIZED BY THE USE OF A PROPANE TORCH UNIT ELIMINATING ALL VEGETATION, DIRT, MOISTURE AND SEEDS. AT THE OPTION OF THE VENDOR, A HERBICIDE MAY BE APPLIED PRIOR TO THE SURFACE TREATMENT APPLICATION. THIS SHALL BE APPLIED FAR ENOUGH AHEAD OF THE SURFACE TREATMENT APPLICATION TO SUFFICIENTLY GIVE THE VEGETATION ENOUGH TIME TO PROPERLY BROWN SO THAT WHEN COMPLETING THE FINAL SWEEPING BEFORE SURFACE TREATMENT NO VEGETATION IS LEFT. VEGETATION REMOVAL SHALL BE CONSIDERED INCIDENTAL TO ALL OTHER BID ITEMS IN THIS SOLICITATION.
- IF A CHEMICAL HERBICIDE IS USED, IT SHALL BE APPLIED ACCORDING TO THE MANUFACTURER'S SPECIFICATIONS. THE VEGETATION SHALL BE TOTALLY BROWNED BEFORE THE CRACK SEAL AND THE SEAL COATING IS INSTALLED. THE PERSON APPLYING THE HERBICIDE SHALL HAVE, OR BE UNDER THE SUPERVISION OF SOMEONE THAT HAS, THE PROPER STATE OF TENNESSEE PESTICIDE APPLICATORS LICENSE

POTHOLE REPAIR

- ALL POTHOLES SHALL BE REPAIRED BEFORE THE CRACK SEAL IS APPLIED. THE CONTRACTOR SHALL SAW CUT THE EXISTING ASPHALT A MINIMUM OF 6" PAST THE POTHOLE AND ASSOCIATED CRACKING IN ALL DIRECTIONS. ALL SAW CUTS SHALL BE PERFORMED TO LEAVE ONLY SQUARE OR RECTANGULAR SHAPED REPAIRS. ANY JAGGED OR MISSHAPED REPAIRS SHALL BE REJECTED AND REPLACED BY THE CONTRACTOR AT NO ADDITIONAL COST TO THE COUNTY.
- THE VENDOR SHALL REMOVE THE ASPHALT AND ANY LOOSE BASE MATERIAL. THE AREA SHALL BE FILLED WITH HOT MIX ASPHALT. ONCE THE ASPHALT HAS BEEN PROPERLY COMPACTED, THE FINAL RESULT OF THE INSTALLATION SHALL PROVIDE EVEN TRANSITIONS TO THE EXISTING AREA AND HAVE JOINTS THAT ARE NOT EXCESSIVE AND A GOOD QUALITY RIDE IS PROVIDED. NO MORE THAN ONE-QUARTER (¼) INCH DIFFERENCE IN HEIGHT SHALL BE ALLOWED FOR THE TRANSITION BETWEEN THE PATCH AREA AND THE ADJACENT AREA. ALL SAWCUTS, REMOVAL, DISPOSAL, PREPARATION, MATERIALS, LABOR AND EQUIPMENT NECESSARY TO COMPLETE PATCHES SHALL BE INCIDENTAL TO THE RESPECTIVE BID ITEMS. COLD PATCH ASPHALT SHALL NOT BE PERMITTED.

ASPHALT EMULSION SEAL COATING

- PRIOR TO APPLICATION OF COATINGS PROTECT ADJACENT CURBS, WALKS, FENCES, BUILDINGS AND OTHER ITEMS IN THE WORK AREA.
- PRIOR TO SEAL COATING ASPHALT REPAIRS AND CRACK SEALING SHALL HAVE SUFFICIENT CURING TIME AS REQUIRED BY THE MANUFACTURER'S SPECIFICATIONS. THE SURFACE SHALL ALSO BE THOROUGHLY CLEANED AND FREE FROM ALL LOOSE MATERIAL, DIRT, AND DEBRIS USING BROOMS, AIR BLOWERS AND/OR POWER SWEEPERS. SURFACE MUST BE DRY BEFORE COATINGS ARE INSTALLED.
- VEGETATION REMOVAL, CRACK SEALING, AND ASPHALT REPAIR REPAIRS SHALL BE COMPLETED AS DESCRIBED ABOVE.
- SCRUB AND CLEAN GREASE, OIL, AND GASOLINE SPOTS WITH SOAP AND WATER AND PRIME ACCORDING TO SEAL COAT MANUFACTURER'S SPECIFICATIONS.

SIGN LEGEND

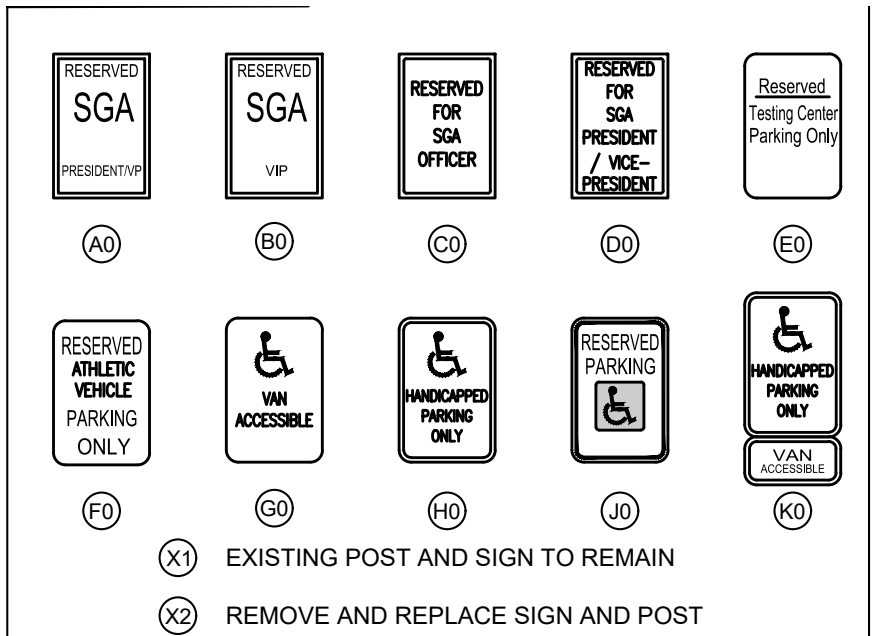

(X) EXISTING POST AND SIGN TO REMAIN
(X2) REMOVE AND REPLACE SIGN AND POST

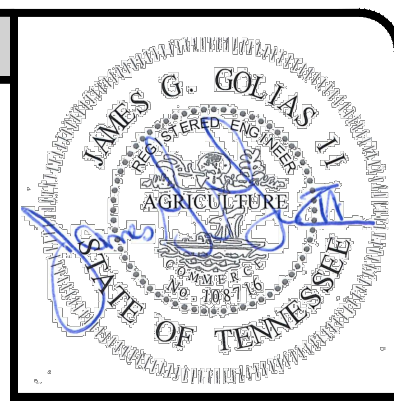

your trusted advisor
consultants

engineers
architects
planners

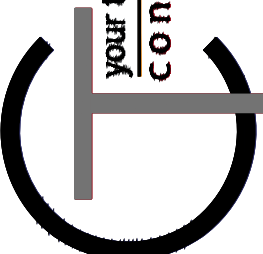

DATE	REVISION	NO	ISSUED FOR:	CONSTRUCTION
			ISSUE DATE:	01/19/2024
			SCALE:	
			DESIGNED BY:	MHOR
			DRAWN BY:	MHOR
			CHECKED BY:	JGCL

MOTLOW STATE COMMUNITY COLLEGE
ADDITIONAL PARKING AND ROADWAY REPAIRS
TULLAHOMA, TENNESSEE 37388

SEC NO. 166021-01-2022A

NOTES & LEGEND

PROJECT NO.	220439
DISCIPLINE	CIVIL
SHEET NAME	C2
SHEET	2
OF	7

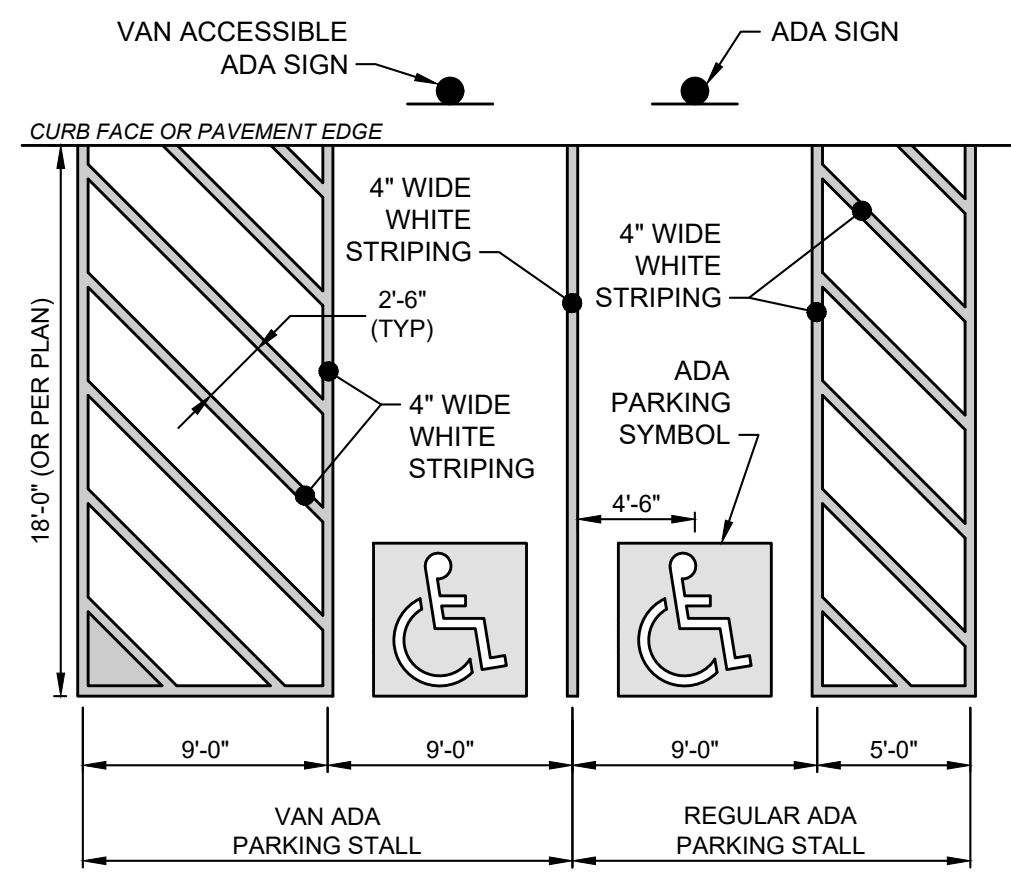

- NOTES:
- THIS DETAIL IS FOR REFERENCE AND DIMENSION CONTROL ONLY; SEE LAYOUT PLAN FOR ACTUAL CONFIGURATIONS AND NOT ALL ITEMS SHOWN MAY APPLY.
 - SEE SEPARATE DETAILS FOR SIGNS AND HANDICAP PARKING SYMBOL.

ADA PARKING LAYOUT DETAIL
SCALE: NONE

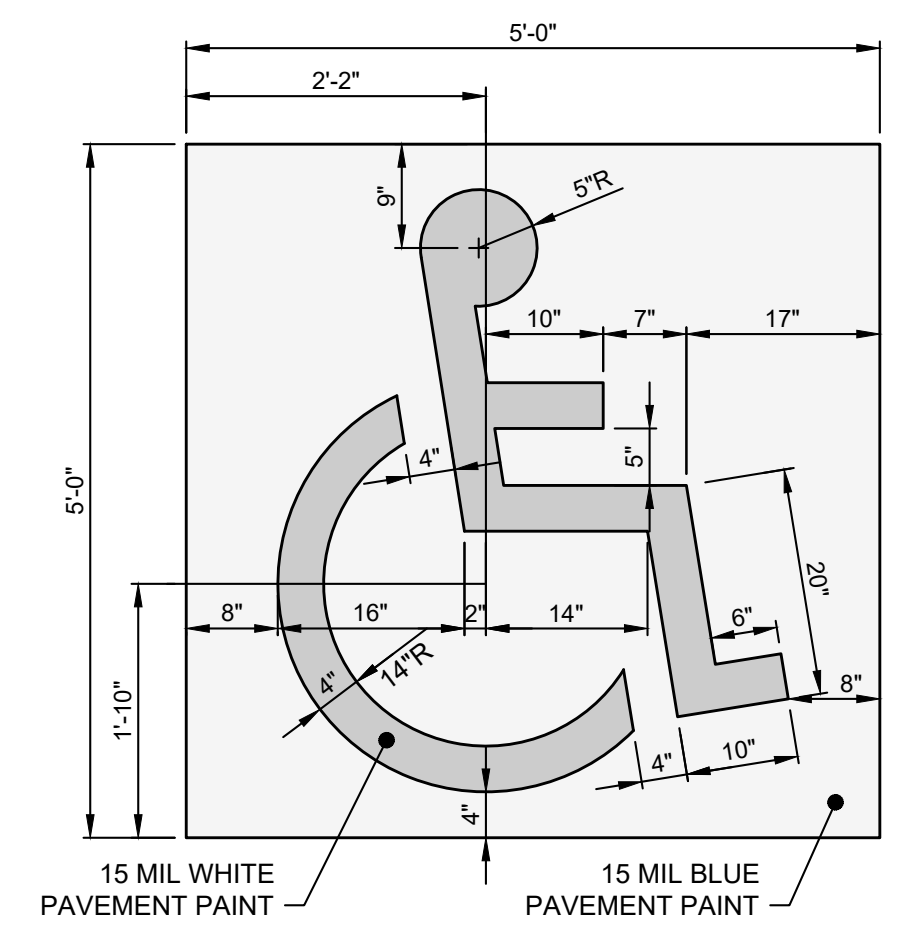

ADA PARKING SYMBOL DETAIL
SCALE: NONE

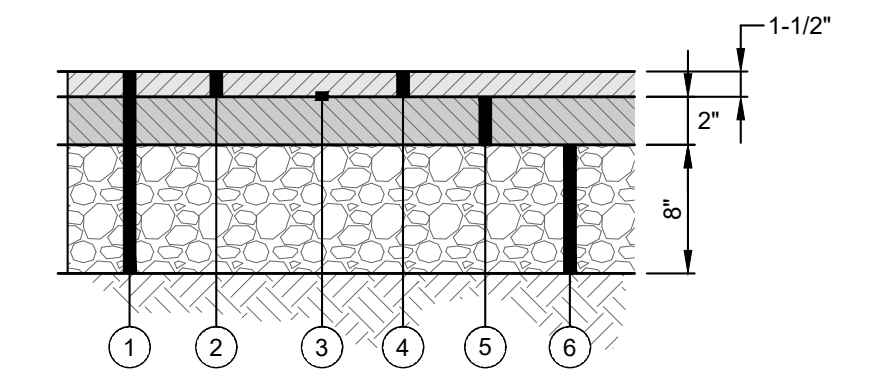

PAVEMENT RESURFACING DETAIL
SCALE: NONE

- EXISTING ASPHALT PAVEMENT SECTION
- ASPHALT MILLING (1.5" TYP.)
- TACK COAT (0.1 GAL/SY)
- 1-1/2" ASPHALT PAVEMENT SURFACE
- EXISTING 2" ASPHALT TO REMAIN
- EXISTING GRAVEL BASE TO REMAIN

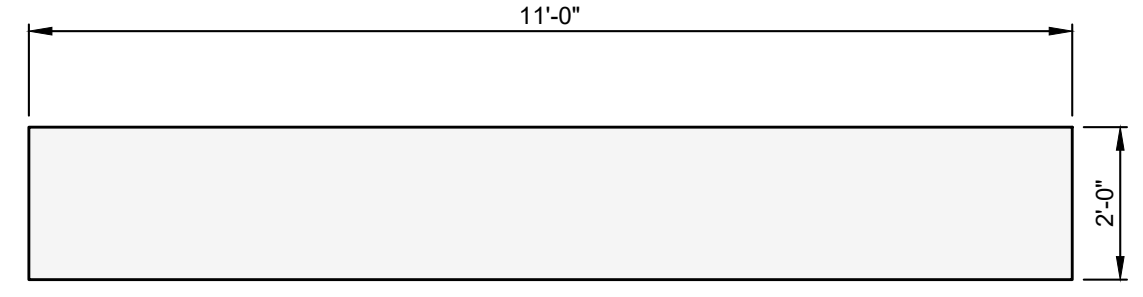

- NOTES:
- SEE LAYOUT PLAN FOR LOCATIONS.
 - STOP BAR TO BE PAINTED WITH THERMOPLASTIC PAINT.

STOP BAR DETAIL
SCALE: NONE

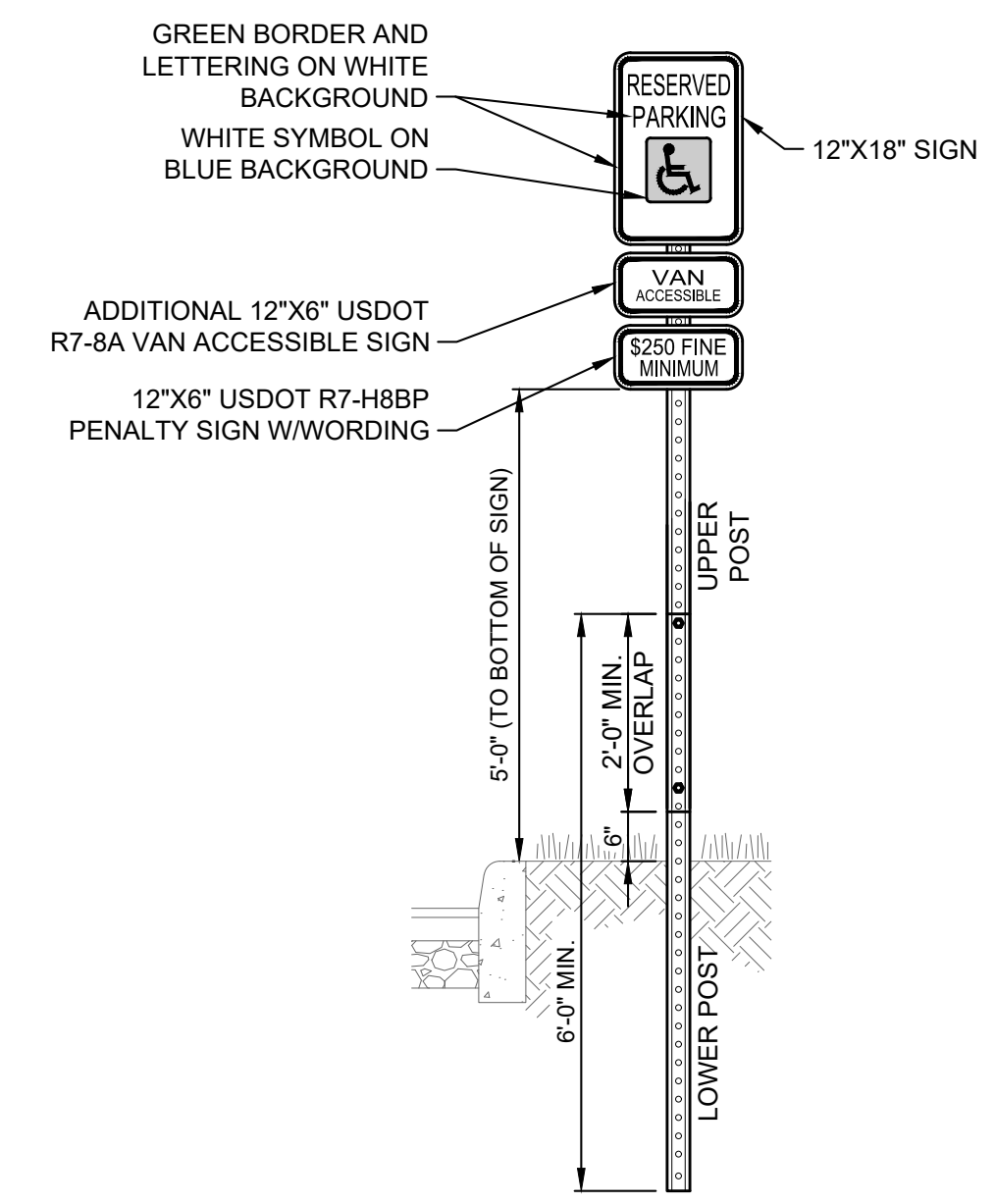

- NOTES:
- POST SHALL BE 2 LB/FT GALVANIZED STEEL U-CHANNEL WITH 3/8" HOLES ON 1" CENTERS.
 - POST SHALL BE PAINTED TO MATCH SIGN.

HANDICAP SIGN W/POST DETAIL
SCALE: NONE

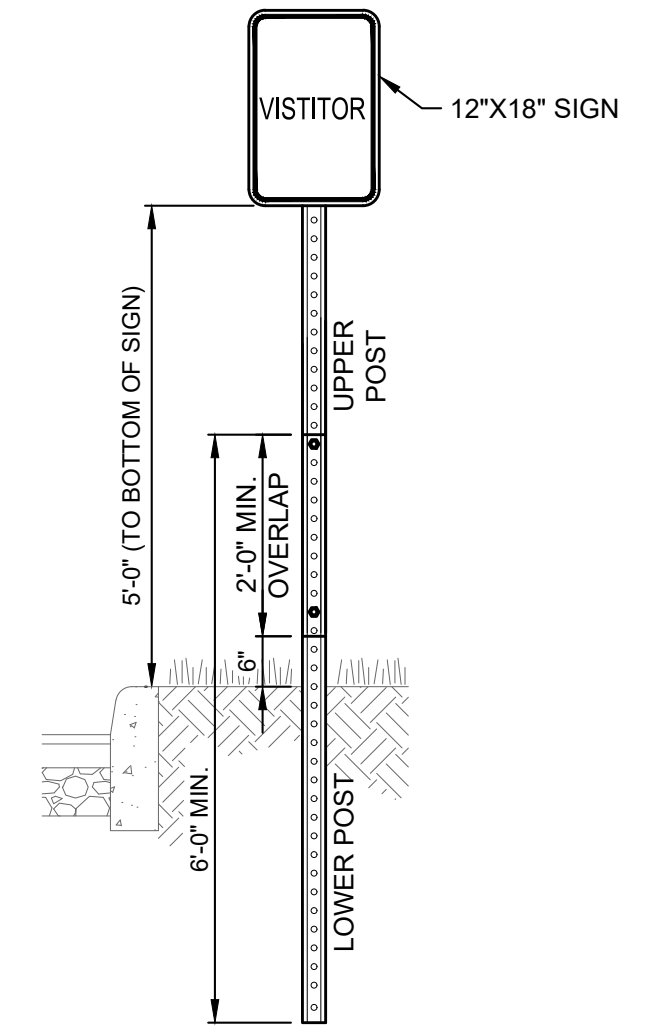

- NOTES:
- POST SHALL BE 2 LB/FT GALVANIZED STEEL U-CHANNEL WITH 3/8" HOLES ON 1" CENTERS.
 - POST SHALL BE PAINTED TO MATCH SIGN.

TYPICAL SIGN W/POST DETAIL
SCALE: NONE

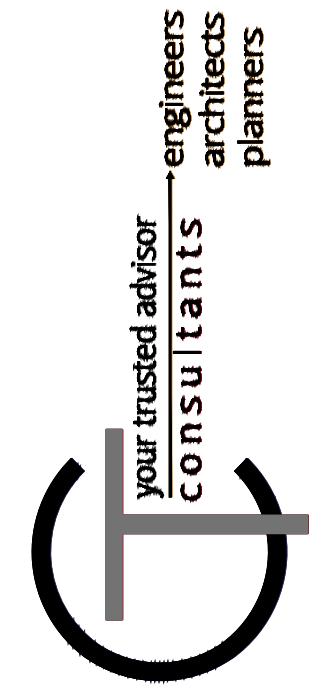
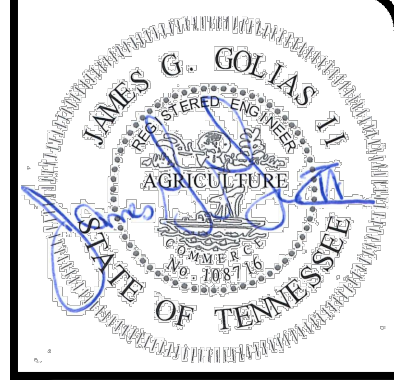

NO	REVISION	DATE

ISSUED FOR: CONSTRUCTION	
ISSUE DATE: 01/19/2024	
SCALE:	
DESIGNED BY: MHOR	
DRAWN BY: MHOR	
CHECKED BY: JGOL	

**MOTLOW STATE COMMUNITY COLLEGE
ADDITIONAL PARKING AND ROADWAY REPAIRS
TULLAHOMA, TENNESSEE 37388**

PROJECT NO.	220439
DISCIPLINE	CIVIL
SHEET NAME	C3
SHEET	3
OF	7

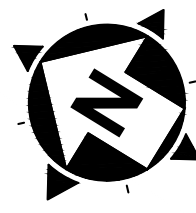

0' 80' 160'
SCALE: 1" = 80'

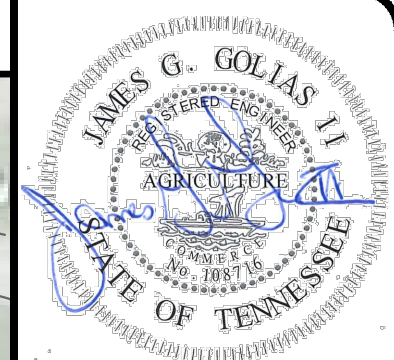

your trusted advisor
CONSULTANTS
engineers
architects
planners

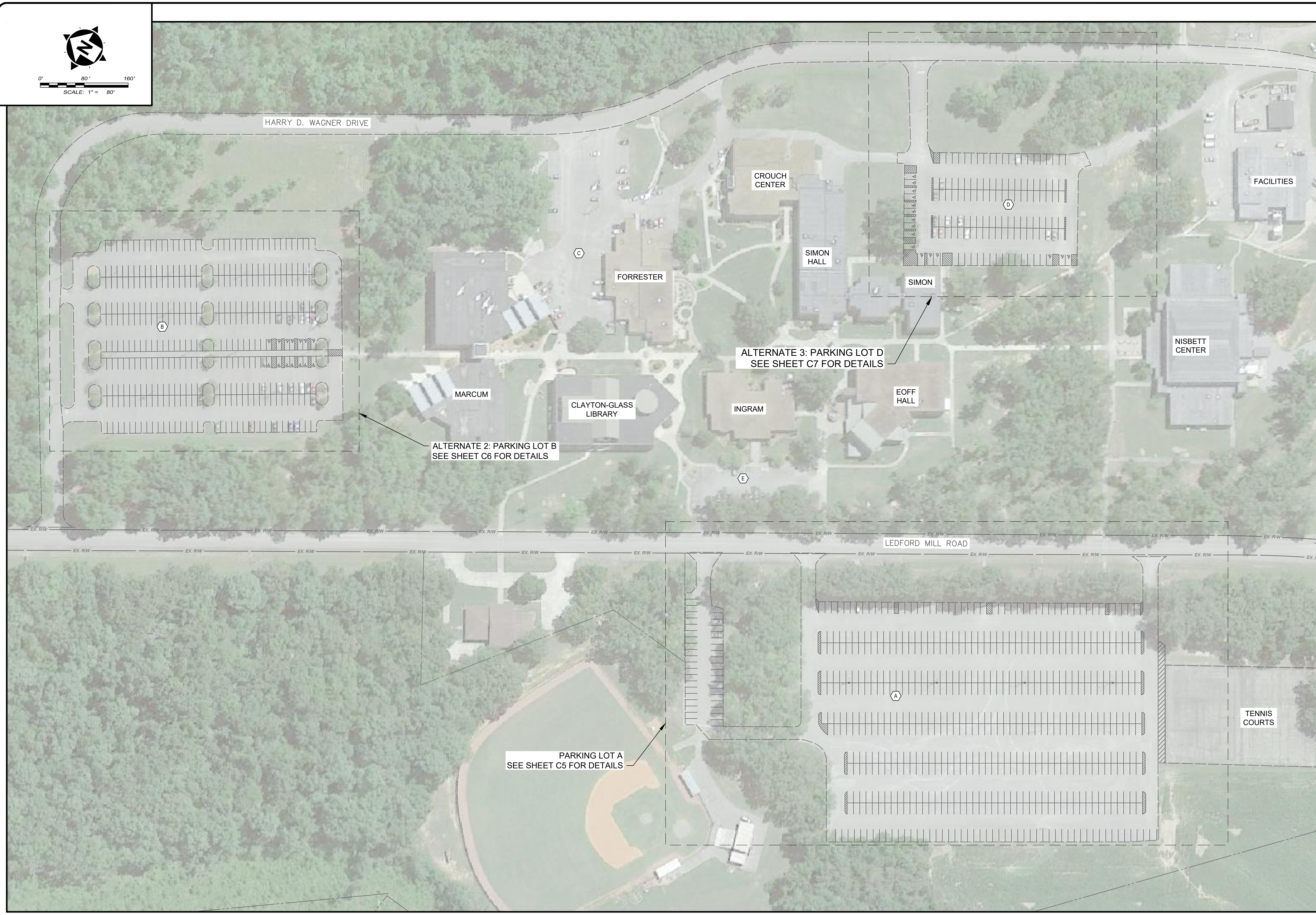
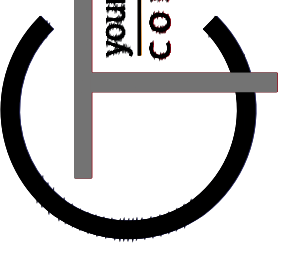

NO	REVISION	DATE

ISSUED FOR: CONSTRUCTION	MHOR	JGOL
ISSUE DATE: 01/19/2024	DESIGNED BY: MHOR	DRAWN BY: MHOR
SCALE:	CHECKED BY: JGOL	

**MOTLOW STATE COMMUNITY COLLEGE
ADDITIONAL PARKING AND ROADWAY REPAIRS
TULLAHOMA, TENNESSEE 37388**

SEC NO. 166021-01-2022A

EXISTING CONDITIONS

PROJECT NO. 220439
DISCIPLINE CIVIL
SHEET NAME C4
SHEET 4 OF 7

SIGNAGE LEGEND				
(A0)	(B0)	(C0)	(D0)	(E0)
(F0)	(G0)	(H0)	(J0)	(K0)
(X1) EXISTING POST AND SIGN TO REMAIN				
(X2) REMOVE AND REPLACE SIGN AND POST				

HATCH LEGEND	
	CRACK SEAL AND SEAL COAT PAVEMENT
	1.5" MILL AND OVERLAY PER DETAIL SHT. 3

PAVEMENT MARKING LEGEND	
	FACULTY/STAFF PARKING ONLY
PAINTED WHITE 12" LETTER HEIGHT	
LEGEND	
	15 PARKING SPACE COUNT

QUANTITY NOTES
QUANTITIES SHOWN ARE FOR REFERENCE. CONTRACTOR IS RESPONSIBLE FOR VERIFYING QUANTITIES AND INFORMING THE OWNER/DESIGNER OF DISCREPANCIES PRIOR TO CONTRACT AWARD.
MILL AND RESURFACE: 1,000 SQ FT
RESEALED PAVEMENT: 233,630 SQ FT
STRIPING: 14,258 LINEAR FT
TRAVERSE STRIPING AREA: 4,283 SQ FT

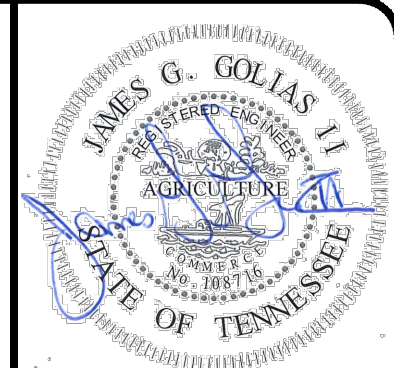
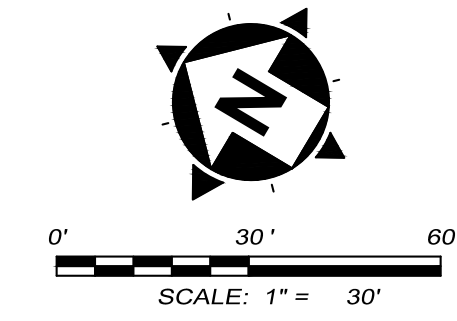

your trusted advisor
CONSULTANTS
engineers
architects
planners

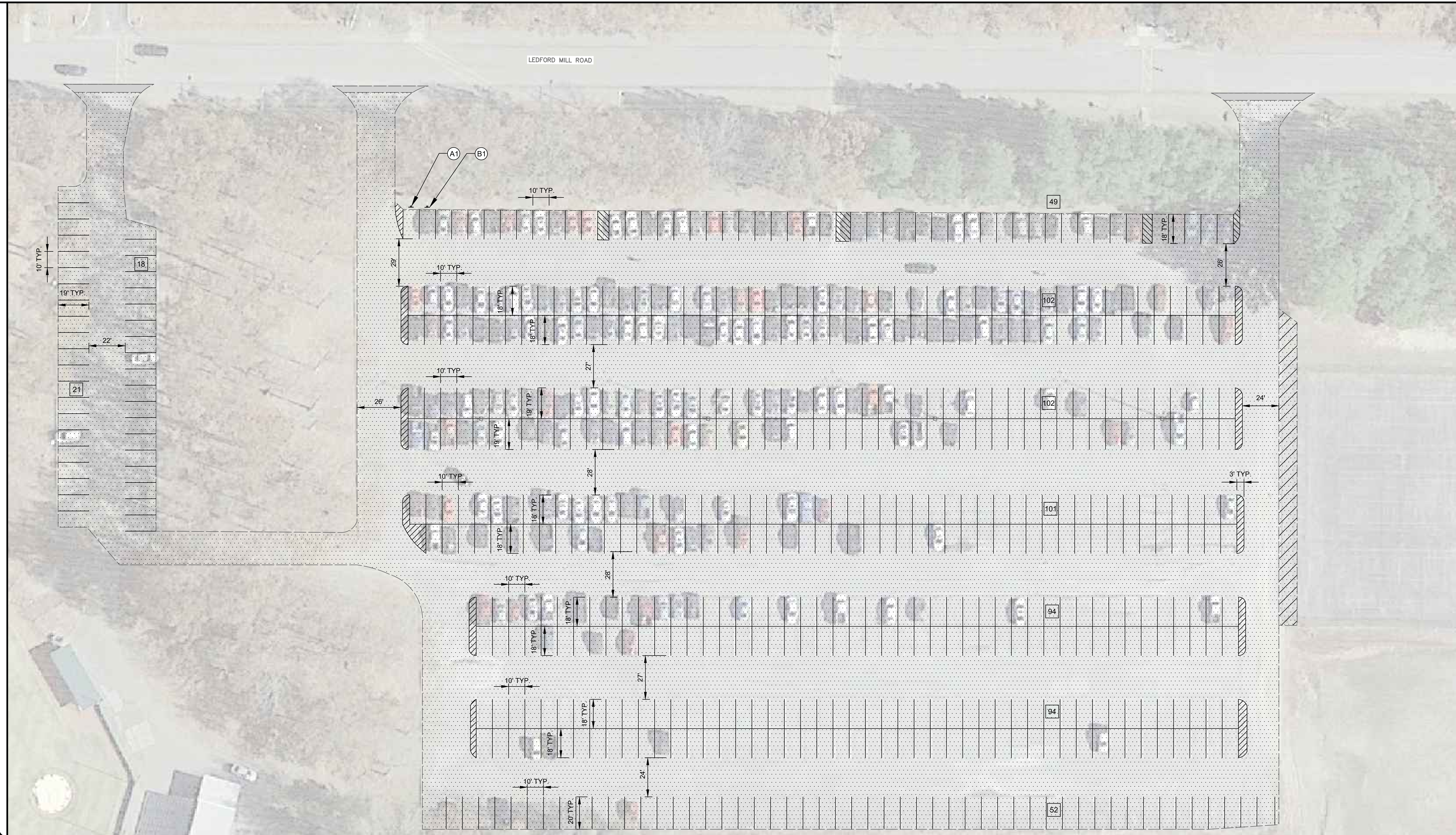

ISSUED FOR:	CONSTRUCTION
ISSUE DATE:	01/19/2024
SCALE:	MHOR
DESIGNED BY:	MHOR
DRAWN BY:	MHOR
CHECKED BY:	JGOL

NO	REVISION	DATE

MOTLOW STATE COMMUNITY COLLEGE
ADDITIONAL PARKING AND ROADWAY REPAIRS
TULLAHOMA, TENNESSEE 37388

SEC NO. 166021-01-2022A

SITE LAYOUT - PARKING LOT A

PROJECT NO.	220439
DISCIPLINE	CIVIL
SHEET NAME	C5
SHEET	5
OF	7

HARRY D. WAGNER DRIVE

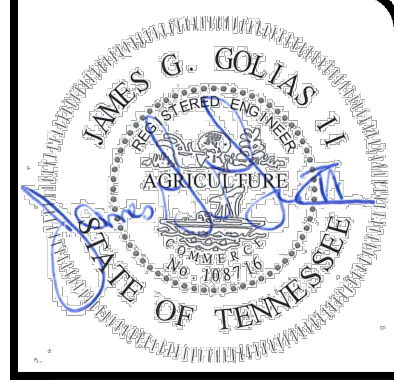
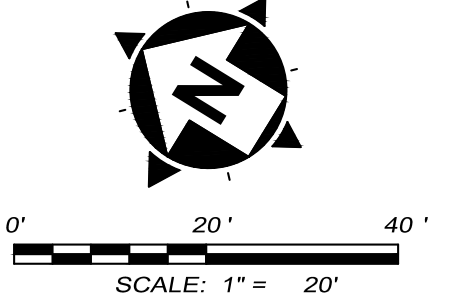

your trusted advisor
engineers
architects
planners
consultants

SIGNAGE LEGEND				
RESERVED SGA PRESIDENTIAL	RESERVED SGA VP	RESERVED FOR SGA OFFICER	RESERVED FOR SGA PRESIDENT / VICE-PRESIDENT	Reserved Testing Center Parking Only
(A0)	(B0)	(C0)	(D0)	(E0)
RESERVED ATHLETIC VEHICLE PARKING ONLY	UN ACCESSIBLE	HANDICAPPED PARKING ONLY	RESERVED PARKING	HANDICAPPED PARKING ONLY VAN
(F0)	(G0)	(H0)	(J0)	(K0)
(X1)	EXISTING POST AND SIGN TO REMAIN			
(X2)	REMOVE AND REPLACE SIGN AND POST			

HATCH LEGEND	
	CRACK SEAL AND SEAL COAT PAVEMENT
	1.5" MILL AND OVERLAY PER DETAIL SHT. 3

PAVEMENT MARKING LEGEND	
	FACULTY/STAFF PARKING ONLY
	PAINTED WHITE 12" LETTER HEIGHT

LEGEND	
	PARKING SPACE COUNT

QUANTITY NOTES	
QUANTITIES SHOWN ARE FOR REFERENCE. CONTRACTOR IS RESPONSIBLE FOR VERIFYING QUANTITIES AND INFORMING THE OWNER/DESIGNER OF DISCREPANCIES PRIOR TO CONTRACT AWARD.	
RESEAL PAVEMENT:	121,170 SQ FT
STRIPING:	7,956 LINEAR FT
ADA PARKING SYMBOLS:	14
STOP BARS:	2
PAINTED LETTERS:	1,242 CHARACTERS
TRAVERSE STRIPING AREA:	1,056 SQ FT

NO	REVISION	DATE

MOTLOW STATE COMMUNITY COLLEGE
ADDITIONAL PARKING AND ROADWAY REPAIRS
TULLAHOMA, TENNESSEE 37388
SEC NO. 166021-01-2022A

ALTERNATE 2 - PARKING LOT B

PROJECT NO.	220439
DISCIPLINE	CIVIL
SHEET NAME	C6
SHEET	6
OF	7

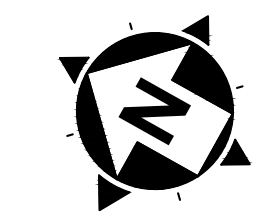
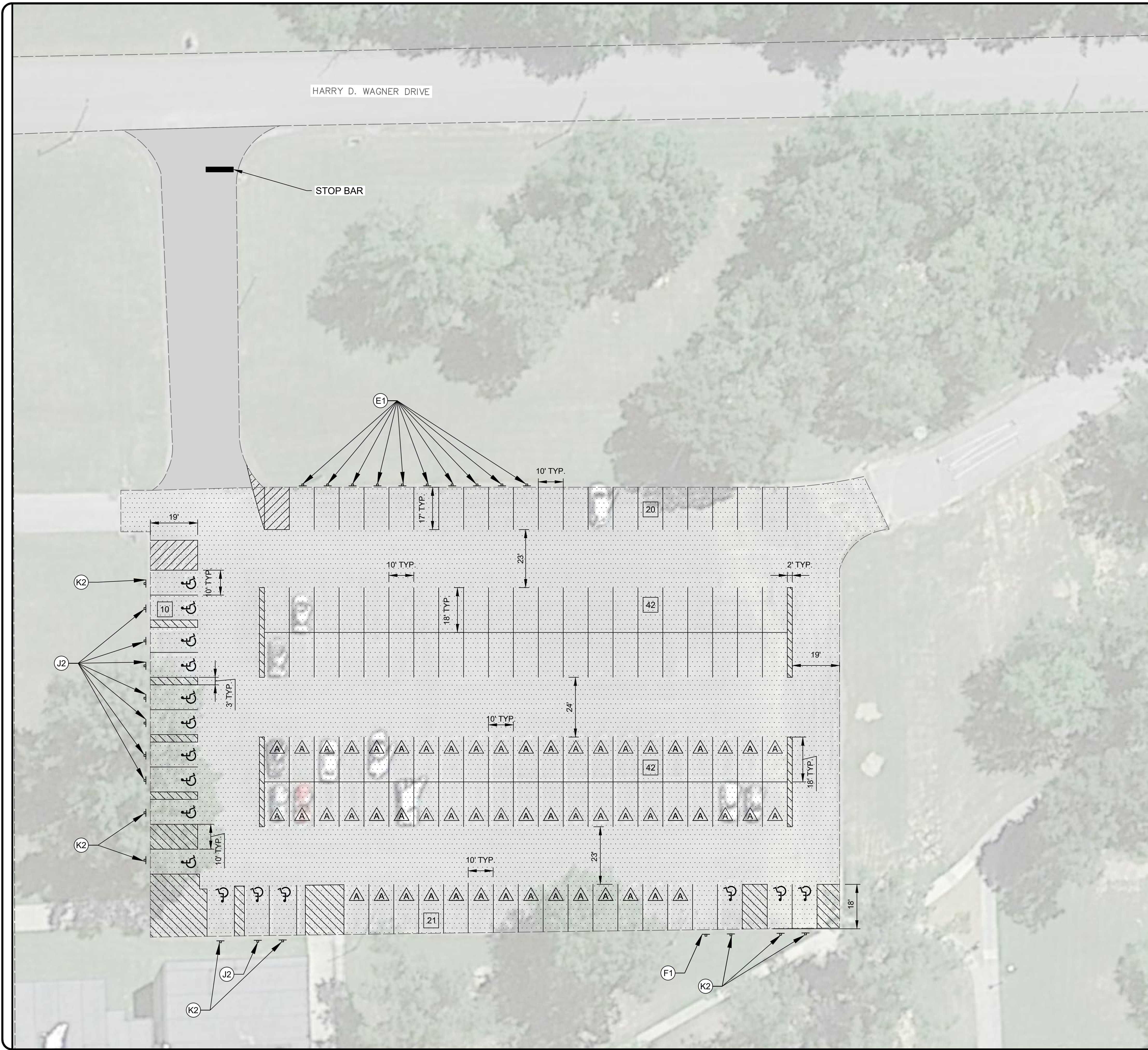

0' 30' 60'
SCALE: 1" = 30'

SIGNAGE LEGEND				
RESERVED FOR PRESIDENTIAL SGA A0	RESERVED FOR VP SGA B0	RESERVED FOR SGA OFFICER C0	RESERVED FOR SGA PRESIDENT / VICE-PRESIDENT D0	RESERVED Testing Center Parking Only E0
RESERVED ATHLETIC VEHICLE PARKING ONLY F0	WHEELCHAIR ACCESSIBLE G0	WHEELCHAIR ACCESSIBLE PARKING ONLY H0	RESERVED PARKING I0	WHEELCHAIR ACCESSIBLE PARKING ONLY VAN K0
X1 EXISTING POST AND SIGN TO REMAIN X2 REMOVE AND REPLACE SIGN AND POST				

PAVEMENT MARKING LEGEND	
	FACULTY/STAFF PARKING ONLY
PAINTED WHITE 12" LETTER HEIGHT	

LEGEND	
	PARKING SPACE COUNT

HATCH LEGEND	
	CRACK SEAL AND SEAL COAT PAVEMENT
	1.5" MILL AND OVERLAY PER DETAIL SHT. 3

QUANTITY NOTES	
QUANTITIES SHOWN ARE FOR REFERENCE. CONTRACTOR IS RESPONSIBLE FOR VERIFYING QUANTITIES AND INFORMING THE OWNER/DESIGNER OF DISCREPANCIES PRIOR TO CONTRACT AWARD.	
MILL AND RESURFACE: 4,500 SQ FT	
RESEALED PAVEMENT: 50,000 SQ FT	
STRIPING: 2,200 LINEAR FT	
ADA PARKING SYMBOLS: 16	
PAINTED LETTERS: 1,344 CHARACTERS	
TRAVERSE STRIPING AREA: 2,444 SQ FT	
STOP BARS: 1	

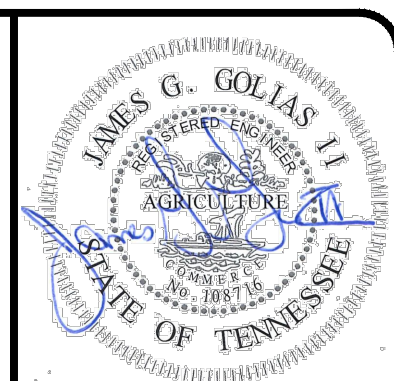

your trusted advisor
consultants
engineers
architects
planners

NO	REVISION	DATE

ISSUED FOR:	CONSTRUCTION
ISSUE DATE:	01/19/2024
SCALE:	
DESIGNED BY:	MHOR
DRAWN BY:	MHOR
CHECKED BY:	JGOL

MOTLOW STATE COMMUNITY COLLEGE
ADDITIONAL PARKING AND ROADWAY REPAIRS
TULLAHOMA, TENNESSEE 37388
SEC NO. 166021-01-2022A

ALTERNATE 3 - PARKING LOT D

PROJECT NO.	220439
DISCIPLINE	CIVIL
SHEET NAME	C7
SHEET	7
OF	7